

RMC Engineering Automated Safety System

Technical Data

Dimensional Specifications

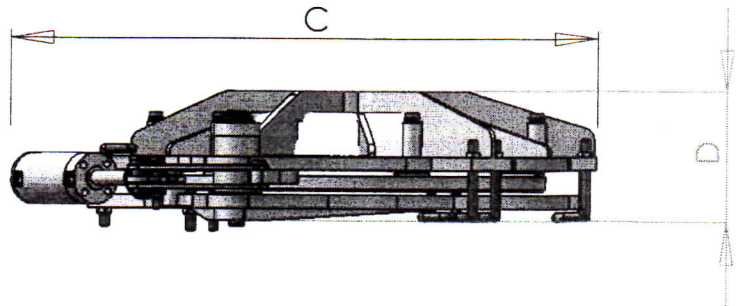
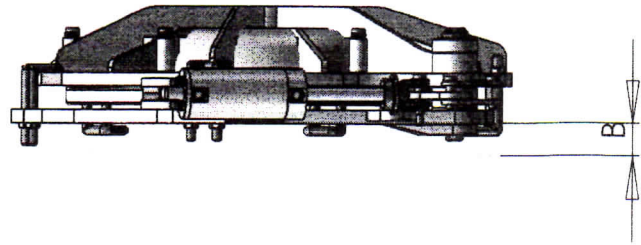
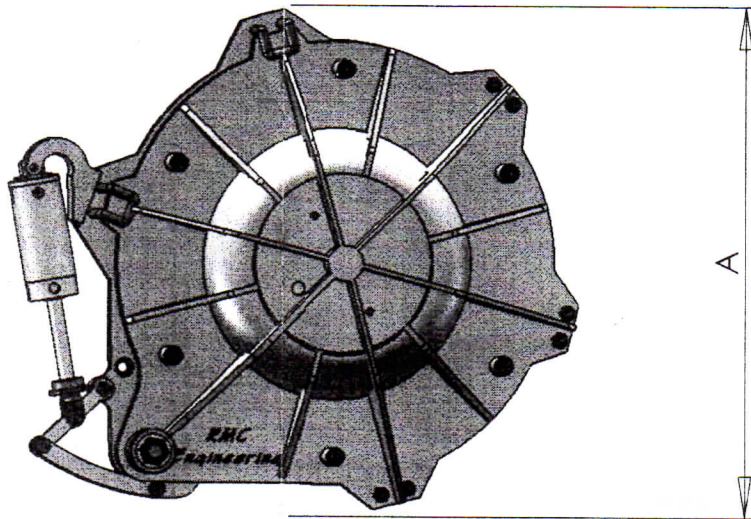

Overall Dimensions:

A.....29.0" (73.66 cm)

B.....1.5" (3.81 cm)(install clearance)

C.....33" (83.82 cm)

D.....6.5" (16.61 cm)

Net Weight.....45 lbs (20.4 kg)

Technical Specifications

Fits All Manhole Ring Openings.....19-5/8" (49.85 cm) to 20" (50.8 cm)

Polyurethane Gasket Temp. Range..... -50° F (46° C) to +200° F (+94° C)

Aluminum Castings..... Alloy 356.1 Heat Treated to T-6 (Brinnell Hardness 98-100)

Airbag Sealing Pressure (to Maintain 15 psi Tank Pressure)..... 80-120 psi

Pressure Tested Tank.....35 psi / Pressure Tested Cover..... 50 psi (Cert #X09120713)

Pneumatic Actuator..... 120 psi

System Requirements/Installation

- Installs on existing camlock ears, no welding required.
- Pressure protection valve included for Auto Lid air supply (rated at 80 psi)
- Color coded bundled tubing matching color coded fittings on lid and control box

Material and Testing Certifications supplied upon request